

West Virginia Office of Miners' Health, Safety and Training

August 7, 2019

Fatal Accident Investigation Report

Electrocution

Kanawha Eagle Mining LLC

South Hollow Preparation Plant

Permit No. L00000966

Region Three-Danville Office

137 Peach Court, Suite 2

Danville, WV 25053

Wayne Pauley, Inspector-at-Large

TABLE OF CONTENTS

General Information.....3-4

Description.....4-8

Findings of Fact.....8-9

Conclusion.....9-10

Enforcement Actions.....10

Accident Timeline.....10-11

Acknowledgment.....12

Recommendations.....12-19

Victim Information.....20

Mine Plant Information.....21

Photographs and Drawings.....22-26

Fatal Accident Investigation Report

Electrocution

Kanawha Eagle Mining LLC

South Hollow Preparation Plant

Permit No. L00000966

GENERAL INFORMATION

The South Hollow Preparation Plant services multiple mines for Kanawha Eagle Mining LLC and was permitted to operate on October 28, 2015. At the time of the accident, the plant employed 45 people who operated and maintained the plant on two 12-hour shifts.

Mr. Michael Scott Davis, a 42-year-old electrician from West Hamlin, WV, was electrocuted at approximately 8:05 a.m. on Wednesday, August 7, 2019. The accident occurred while Mr. Davis was making repairs to the slope belt drive A starter circuit in the Motor Control Center (MCC) room on the eighth floor of the preparation plant.

Mr. Davis had been employed at the South Hollow Plant for approximately 14 years and 5 months. Mr. Davis obtained his electrical certification on January 27, 2012. He had his last annual refresher on September 15, 2018 and had electrical retraining on October 12, 2018.

At approximately 8:12 a.m., the Kanawha County Ambulance Authority received a call from the South Hollow Plant informing them that Mr. Davis had been in an accident and dispatched a crew to the mine site. The West Virginia Division of Homeland Security and Emergency Management (WVDHSEM) was notified of the accident at 8:20 a.m. Wayne Pauley, Inspector-at-Large for the Danville Office of WV Miners Health, Safety and Training, was notified at approximately 8:40 a.m. about the accident by WVDHSEM. A verbal control order was issued by Mr. Pauley at approximately 8:45 a.m. in accordance with 22A-2-68 to prevent further injuries and to preserve the accident scene. A joint investigation was initiated by the Office of West Virginia Miners Health, Safety

and Training (OMHST), the Mine Safety and Health Administration (MSHA) and Kanawha Eagle company representatives.

DESCRIPTION

During the evening shift, starting at 7:00 p.m. on Tuesday, August 6, 2019 and ending at 7:00 a.m. on Wednesday, August 7, 2019, the crew encountered problems with restarting the slope belt. At approximately 11:30 p.m., the evening shift plant operator, Joshua Glenn Farley, and the evening shift plant foreman/electrician, Richard Muncy, turned the slope belt off after the Eagle Mine had told them that they were finished using the slope belt. Mr. Muncy then left to go to the warehouse to get supplies for the plant. A short time later the Eagle Mines called back and said that they would like to have the slope belt running. Mr. Farley attempted to restart the belt but was unsuccessful. Mr. Farley said that the belt would try to start but would not come up to full speed. The pony motor would start and the slope belt would start turning, but the main drive motors for the slope belt would not start. There were no faults indicated on the control panel. Mr. Farley then contacted the evening shift electrician, Darrell Atkins, and informed him of the situation.

Mr. Atkins went back to the MCC room to check on the problem. The MCC room is located on the eighth floor of the preparation plant and is where the belt controller and the power circuit for the slope belt is located. Mr. Atkins began trouble shooting the slope belt controller and saw that the problem was with the starter circuit for the slope belt drive A motor. Mr. Atkins continued to work on the problem with the belt but was not making any head way so he decided to wait on his supervisor, Mr. Muncy, to return from the warehouse so he could assist him.

Mr. Muncy and Mr. Atkins both returned to the eighth floor to continue troubleshooting. They decided to try to run the belt in "jog mode" to see if it would run. This attempt was unsuccessful, but they could hear a contactor chattering inside of the cabinet for the slope belt A motor when the belt was trying to start. They then decided to try to utilize the test circuit to isolate the problem. The test circuit allows you to pull the main power off the circuit and then apply 110-volt control power to the circuit by using an external power source. This is accomplished by using an extension cord and plugging it into the test receptacle. When the test mode is utilized there is no high voltage power

inside of the cabinet. Only 110-volts are present. They attempted this several times, but they could not get the test circuit to function.

Mr. Muncy and Mr. Atkins continued to troubleshoot on the slope belt motor A starter circuit until approximately 4:00 a.m. Wednesday morning at which time Mr. Muncy made the decision to call someone for help with the problem because it was getting late into his shift. Mr. Muncy was able to contact Richard Cypress who worked in the maintenance department. They decided that the best course of action would be to change out the vacuum contactor for that circuit based upon their findings.

Mr. Muncy did not have a new contactor available, so he and Mr. Atkins left the plant building and found a similar contactor in a pump house on the property that was not being used at the time. They removed the contactor from the unused pump circuit and took it back to the plant to install it in the slope belt motor A cabinet.

Upon arriving back on the eighth floor of the plant, Mr. Muncy and Mr. Atkins began installing the vacuum contactor. The disconnects were pulled for the slope belt A motor circuit and Mr. Muncy removed the high voltage fuses from the cabinet, but Mr. Muncy nor Mr. Atkins locked and tagged the disconnect. At this time, Mr. Atkins began removing the contactor from the cabinet. They continued to work until approximately 7:00 a.m. At this time Mr. Muncy told Mr. Atkins that it was close to his quitting time and to finish up what he was doing and then go home. Mr. Muncy stayed to help the day shift finish the job.

At approximately 7:00 a.m. the day shift attended their safety meeting in the mine office. After the safety meeting Michael Scott Davis, victim/dayshift electrician, and Travis Myers, dayshift electrician, went to the eighth floor of the plant to help finish the repairs on the slope belt.

Upon arriving on the eighth floor, Mr. Davis and Mr. Myers met Mr. Muncy inside of the MCC room. Mr. Muncy briefed them on the progress of the job and on the events that had unfolded throughout the night. At this time, Mr. Muncy had the old contactor out of the cabinet which was still not locked and tagged. They also checked the contactor to make sure that it was compatible to the one that they were replacing. They began installing the replacement contactor without locking and tagging the disconnects.

While Mr. Davis was installing the contactor, Mr. Clifton White, operations manager, called and spoke to Mr. Muncy about how long it was going to take to finish the job. Mr. Muncy told him that they would probably be 15 or 20 minutes. Bill Clendenen, the dayshift plant foreman/electrician, arrived at the MCC room around this time, Mr. Muncy briefed Mr. Clendenen on the status of the job and the events leading up to this point. At this time the disconnects still were not locked and tagged.

Mr. Davis finished installing the replacement contactor. Mr. Myers then installed the high voltage fuses back into the circuit and they shut the door on the cabinet. Mr. Davis attempted to put the disconnect blades in but the disconnect handle would not move. It was stuck in the open position and would not allow the blades to be closed to re-energize the circuit. They made sure that the cabinet door was shut tight and all the bolts were tightened and tried it again, but it was still stuck in the open position.

At this time, they decided that the linkage for the disconnect handle was the problem. This linkage is located inside of the high voltage cabinet. There are two sets of linkage inside of the cabinet. Those two sets of linkages work together, but each has its own purpose. The top linkage is used to connect the disconnect handle which is located on the outside of the cabinet to the disconnect mechanism which is located inside of the high voltage compartment. This allows you to open and close the disconnect from the outside of the cabinet. The bottom linkage is used as a safety device. It is connected to a metal plate on the vacuum contactor that was changed. Its function is to keep someone from opening the disconnect when the contactor is closed and the circuit is under a load. This is accomplished by the linkage being operated when the contactor closes and it pulls a safety latch that will not allow the disconnect to be opened until the contactor opens. (Refer to photo 1.5 on page 26 of this report.)

Mr. Davis then opened the door of the high voltage compartment. He and Mr. Muncy inspected the linkage and determined that the bottom linkage was the problem and needed to be adjusted. Mr. Davis proceeded to make the adjustments without locking and tagging the disconnects. While Mr. Davis was making the adjustments, Darrell Scott Williams, Maintenance Planner, entered the MCC room. Mr. Williams had come to the room to get information off the replacement contactor which had been installed. Glenn Stover, Maintenance

manager, was wanting this information to make sure that it was the correct contactor. Mr. Williams then left the room.

Mr. Muncy then noticed that the disconnect handle (that was never locked and tagged) to the circuit that was being worked on looked to be in the closed or "up" position. This would mean that the disconnects would be closed and that the circuit, which they were working on, was energized. Mr. Muncy went over to investigate and looked inside of the cabinet. Mr. Muncy said that when he looked in the cabinet it appeared that the disconnect mechanism was in the closed or partially closed position. Mr. Muncy said that he told Mr. Davis that he did not like the way that it looked and repositioned himself behind Mr. Davis so he could get a better look. At this time Mr. Muncy said that Mr. Davis made a noise and he could tell that he had contacted power and was being shocked. Mr. Muncy started to grab Mr. Davis but realized that he too would be shocked if he contacted Mr. Davis. Mr. Muncy told Mr. Clendenen to throw him the high voltage gloves so that he could get him out of the power. Mr. Clendenen did, and Mr. Muncy donned the gloves and pulled Mr. Davis away from the cabinet.

Mr. Williams was outside of the room and heard the commotion and ran in. After he saw what had took place, he said he was going to knock the power and left. Mr. White was in the control room and heard someone call out on the radio to call an ambulance, which he did so. Mr. Myers also left the room to get the AED (automated external defibrillator). Mr. Muncy checked for breathing and a pulse but found none. Zachary Bailey, a scales technician for Kanawha Scales, was outside and entered the MCC room to offer assistance with first aid efforts. Mr. Muncy and Mr. Bailey then began CPR on Mr. Davis.

Mr. Clendenen got on the elevator to take it to the first floor to pick up Mr. Myers and the AED. After the elevator had descended three floors the power went off. Mr. Clendenen called out on the radio and told Mr. Williams to put the power back on because they needed the elevator, once the power was restored, the elevator returned to the eighth floor on its own. Mr. Clendenen then traveled down to the first floor and picked up Mr. Myers and the AED and returned to the eighth floor.

They took the AED into the MCC room where Mr. Myers and Mr. Bailey were still performing CPR. They applied the AED to Mr. Davis and it advised them to shock Mr. Davis three different times which they did. At this time the ambulance had arrived on scene and they relinquished Mr. Davis's care to them.

Mr. Davis was transported to CAMC Memorial Hospital in Charleston, WV by the Kanawha County Emergency Ambulance Authority where he was later pronounced deceased.

FINDINGS OF FACT

1. At the time of the accident, there were four people inside of the MCC room located on the 8th floor of the preparation plant. They were Michael Scott Davis (victim/dayshift electrician), Travis Myers (dayshift electrician), Richard Muncy (evening shift plant foreman) and Bill Clendenen (dayshift plant foreman).
2. Mr. Davis had been a certified electrician since January 27, 2012.
3. Mr. Myers has been a certified electrician since 2013.
4. Mr. Muncy has been a certified electrician since November 2, 2000.
5. Mr. Clendenen has been a certified electrician since November 10, 1976.
6. Mr. Atkins has been a certified electrician since 2010.
7. The voltage that was present on the contactor that Mr. Davis was working on was 4,160 volts.
8. The vacuum contactor that was replaced was determined to be faulty. This contactor was tested by the technical support group with MSHA and was found to have a faulty holding coil on the contactor.
9. The disconnect for the circuit that was involved in the accident was found to be in the closed position. The handle of the disconnect was stuck in this position due to the linkage that connects the vacuum contactor to the safety latch being severely out of adjustment.

10. The disconnect for the circuit that was involved in the accident was never locked and tagged.
11. The high voltage electrical gloves that were found inside of the MCC room were sent off for testing by OMHST. The gloves passed all testing.
12. The test circuit for the slope belt drive motor A starter circuit was not functional at the time of the accident. This was due to a set of faulty auxiliary contacts located on the disconnect mechanism for this circuit. Mr. Muncy and Mr. Atkins attempted to utilize this feature but were unable to.
13. The National Electric Code states that service disconnects must be readily accessible and be capable of disconnecting all three phases simultaneously. This facility did not have the proper means to disconnect the incoming high voltage power to the MCC structures located on the first and eighth floor of the preparation plant.
14. Work was being performed on electrical circuits at this operation without having them properly locked and tagged out in accordance with West Virginia Code Chapter 22A, Article 2, Section 40(19).
15. Work other than trouble shooting or testing was being performed on energized electrical circuit at this operation.
16. On August 7, 2019, Michael Scott Davis was electrocuted in the MCC room located on the 8th floor of the South Hollow Preparation Plant while making repairs on the slope belt motor A starter circuit.

CONCLUSION

On August 7, 2019, Michael Scott Davis was electrocuted on the 8th floor of the South Hollow Preparation Plant while performing work inside of the energized cabinet for the slope belt drive motor A starter circuit. The circuit was not locked

and tagged out as required by West Virginia Code Chapter 22A, Article 2, Section 40(19).

ENFORCEMENT ACTIONS

The following enforcement actions were taken as a result of the investigation.

A non-assessed control order was issued in accordance with Chapter 22A, Article 2, Section 68 of the West Virginia Code to prevent further injuries and to preserve the accident scene.

There were eleven (11) violations issued as a result of the investigation. Ten (10) of the violations were regularly assessed and one (1) was recommended for special assessment.

The following violation was recommended for special assessment.

(Violation #1) **Special Assessment**, Chapter 22A, Article 2, Section 40(19): No electrical work shall be performed on low-, medium-, or high-voltage distribution circuits or equipment, except by a qualified person or by a person trained to perform electrical work and to maintain electrical equipment under the direct supervision of a qualified person. Disconnecting devices shall be locked out and suitably tagged by the persons who perform such work, except that in cases where locking out is not possible, such devices shall be opened and suitably tagged by such person who installed them, or, if such persons are unavailable, by persons authorized by the operator or his agent. High voltage electrical disconnecting devices were not locked out and suitably tagged before person(s) performed electrical work inside of the slope belt motor A high voltage cabinet. It was possible to disconnect the circuit(s) at two locations, the local disconnect on the cabinet and disconnect(s) located at the main 5000 KVA substation. Such devices were not opened, locked out and/or suitably tagged by such persons working on the electrical circuit. This is a violation of a safety statute of a serious nature and involved a fatality.

ACCIDENT TIMELINE

Tuesday August 6, 2019:

The evening shift crew started normal duties at the preparation plant at 7:00 p.m.

At approximately 11:30 p.m. the North Eagle mines contacted the South Hollow Plant and informed them that they were done with the slope belt and it could be shut down for the evening.

Wednesday August 7, 2019

At approximately 12:00 a.m. the control room operator attempted to start the slope belt back up and realized that there was a problem with the belt.

At approximately 4:00 a.m., mine personnel decided that the problem with the slope belt was the vacuum contactor for the slope belt A drive motor and started the process of changing it.

At 7:00 a.m. the dayshift crew started their shift.

At approximately 8:05 a.m., Michael Scott Davis was electrocuted while making these repairs.

The Kanawha County Ambulance Authority dispatched emergency services at approximately 8:12 a.m.

The mines notified the WVDHSEM at 8:20 a.m.

The WVDHSEM notified Wayne Pauley, Inspector at Large for Region 3 OMHST, at approximately 8:40 a.m.

At approximately 8:45 a.m., Wayne Pauley dispatched Mark Keyser, Electrical Inspector/Accident Investigator for Region 3 OMHST, and Randy Carter, Roof Control Specialist/Accident Investigator for Region 3 OMHST, to the scene of the accident.

At approximately 8:45 a.m., Wayne Pauley contacted the mine site and informed them that they had been placed under a verbal control order under the authority of the Office of WVMHST.

At approximately 9:15 a.m., Mark Keyser and Randy Carter with the Region 3 OMHST arrived at the South Hollow Plant and began the investigation with the assistance of other WVOMHST employees.

Acknowledgment

The West Virginia Office of Miners Health, Safety and Training gratefully appreciates the cooperation of the employees and management of Kanawha Eagle Mining and the Mine Safety and Health Administration during the process of this investigation.

Recommendations

Recommendations are listed on pages 13-19.



August 9, 2019

Mr. Scott Mandeville
District Manager
MSHA District 4
100 Bluestone Road
Mountlope, WV 25880-1000

Mr. Eugene White
Director of West Virginia Office of Miners Health and Safety
#7 Players Club Drive-Suite 2
Charleston WV, 25311-1626

RE: South Hollow Plant
MSHA 103K Order 9169201/WVOMHS&T Control Order Dated 08/07/2019
MSHA ID: 46-03085
WVOMHST ID: L-00000966
Kanawha County, WV

Mr. Mandeville, Mr. White,

Kanawha Eagle; South Hollow Plant is requesting modification to the 103K order 9169201 / VVI/OMHS&T Control Order to allow the operator to perform the following items.

- Install a Gang Operated Air Brake (GOAB) switch at the substation on the 4160 high voltage feed to the plant. This will allow for a user-friendly process to remove the high voltage power supply to the plant in a timely manner.
 - o GOAB switch will be installed prior to restoring the high voltage power feed to the plant.
- Pursue one of the following options
 - o Deconstruct the current Allen Bradley high voltage cabinet in the 8th floor MCC Room and install a newer model Allen Bradley high voltage cabinet with built in service disconnect that Kanawha Eagle currently has onsite. This option is only applicable if Rockwell Automation verifies that the newer model cabinet is compatible with the current components.
 - o Make needed repairs to ensure the existing Allen Bradley high voltage cabinet on the 8th Floor MCC room is working properly until adequate equipment with a service disconnect can be obtained and installed.
- Construct additional space onto the existing 8th floor MCC room to obtain adequate clearance for the above-mentioned options.
- Make needed repairs to ensure the linkage that controls the functions of the micro switches that enables the testing system in the Allen Bradley high voltage cabinets on the 1st floor MCC room are working properly.
- Planning and engineering of a disconnect switch for the Allen Bradley high voltage cabinet in the basement MCC will begin immediately and will be completed upon the availability of parts

The South Hollow Plant has a non-represented workforce. No hourly employee at the plant has volunteered or accepted the role of miners' representative. This notification has been posted at the mine office for review. If you should have any questions, please do not hesitate to call me at (304) 541-5365.

Respectfully,

Chris Williams
Safety Manager

Chris Williams
7/26/19

approved Eugene White 8/9/19

PO Box 189 Comfort WV 25049

5:30 pm



Kanawha Eagle Mining, LLC P O Box 189
Comfort, WV 25049
Phone: (304) 837-5400

August 12, 2019

Mr. Eugene White
Director of West Virginia Office of Miners Health and Safety
#7 Players Club Drive-Suite 2
Charleston WV, 25311-1626

RE: South Hollow Plant
WVOMHS&T Control Order Dated 08/07/2019
MSHA ID: 46-03085
WVOMHST ID: L-00000966
Kanawha County, WV

Kanawha Eagle's, South Hollow Plant provides the following update of the completed steps and requests review from the agencies to evaluate the process.

- Installation of a Gang Operated Air Brake (GOAB) switch at the substation on the 4160 high voltage feed to the plant.
- Repairs to ensure the existing Allen Bradley high voltage cabinets micro-switches are functional.
- Repairs to ensure the linkage that controls the functions of the micro switches that enables the testing system in the Allen Bradley high voltage cabinets on the 1st and 9th floor MCC rooms are working properly.

With this update, South Hollow Plant is requesting modification to the WVOMHS&T Control Order to allow additional steps to be completed allowing restoration of high voltage power to allowing testing of the power circuits. South Hollow Plant requests that once verifications of this work have been completed, the plant may begin operations in a modified manner until additional long-term controls can be implemented.

It is requested that the below listed safety precautions and training outline be added as an addendum to the current Comprehensive Mine Safety Program for the South Hollow Plant. The operator will notify WVOMHS&T of any completed changes and request modification to the CMSP as needed.



Kanawha Eagle Mining, LLC
P.O. Box 189
Comfort, WV 25049
Phone: (304) 837-5400

Immediate Actions:

The following safety precautions are proposed to be utilized as a near-term solution and will be implemented immediately.

- All South Hollow Plant Electricians and Plant Supervisors will be required to maintain a lock on their person while working in the plant.
- If an electrician is required to work on the high voltage inside the plant, high voltage feed entering the plant, must be removed prior.
 - This will be accomplished by locking and tagging out the newly installed Gang Operated Air Brake (GOAB) switch at the substation.
 - All high voltage cabinets (including 3rd floor MCC room) will have a locking mechanism installed that requires a single key to gain access to open the doors.
 - The key will be acquired by opening a lock box maintained at the GOAB switch. Access to the lock box will require the GOAB to be in the opened position which in turn disconnects the high voltage plant feed.
 - The key acquired at the lock box will serve as the single key to access the high voltage cabinets mentioned above.
 - When the GOAB switch is in the closed position, the lock box will remain shut. A substation key will remain on the GOAB, locking it in the closed position. Certified electricians are the only employees that have access to the substation key.
- All parties involved in the repair/troubleshooting will have their own lock on the GOAB switch while work is being performed.
 - All Electrician working on the high voltage circuit will be required to place their individual lock and tag on the circuit.
 - The supervisor on duty will also place their individual lock and tag on the circuit.



Kimlwhll fAQitt Mining, LLC P O Box 189
Comfort, WV 25049
Phone: (304) 837-5400

- Training
 - o All miners working at South Hollow plant will be retrained on the lock and tag out procedures prior to the individual miners resuming an operational role within the plant. The training will be documented on a 5000-23.
 - o All current certified electricians, newly employed electricians, and any contract electrician working on high voltage systems, will attend an electrical safety course highlighting the hazards involved when working near energized sources. This course will be conducted by the company engineers and electrical experts and will involve hands on instruction.
 - Training will be conducted on site with BHM Engineers, Kanawha Eagle Maintenance Managers, and the BHM Training Department. The training will consist of locations and methods to disconnect HV inputs, Lock and Tag procedures for HV circuits, familiarization with HV cabinets, and test circuits.
 - Training will be conducted on the procedures of locking and tagging the incoming high voltage feed to the plant utilizing the newly installed GOAB switch.



Kanawha Eagle Mining, Inc. P O Box 189
Comfort, WV 25049
Phone: (304) 837-5400

Potential Long-Term Options

Due to the required engineering and research to be conducted prior to installation of a long-term solution, Kanawha Eagle is requesting additional time to make a final decision.

A visual disconnect system will be installed and maintained on the high voltage feed entering the 1st and 3rd floor MCC rooms. The following options are being considered as an added engineering control.

- Locking Visual Disconnect
 - o Locking mechanism on disconnect that would release a single key when the disconnect is in the open position.
 - o This key would be required to open the locks on the cabinet doors to gain access inside the cabinet.
 - o This applies to the 3rd floor MCC room as well.
- Power Tripping Interlock Switches
 - o Install switches inside of each high voltage cabinet that would automatically trip the 4160 feed.
 - o This applies to all 4160 cabinets installed in plant.
- Other Potential Options
 - o All options have yet to be explored. Thru the research process of the above a better solution may be determined.
 - o If other solution is proceeded with, the 3rd floor MCC room will have additional protection equal to the other 4160 cabinets.

Kanawha Eagle will notify WVOMHS&T in writing by or on 8/19/19 of the most practicable solution as well as a time frame estimate on completion.

The South Hollow Plant has a non-represented workforce. No employee or other person has volunteered or accepted the role of miners' representative. This notification has been posted at the mine office for review. If you should have any questions, please do not hesitate to call me at (304) 837-5521 or (304) 989-9249.

Respectfully,

A handwritten signature in black ink that reads "Clifton 'Scooter' White".

Clifton "Scooter" White
Operations Manager



Kanawha Eagle Mining, LLC P O Box 130
 Canaan, WV 26041
 Phone: (304) 841-4400

August 19, 2019

Mr. David S. Mandeville
 District Manager
 MSHA District 4
 100 Bluestone Road
 Mt. Hope, WV 25880

Mr. Eugene White
 Director of West Virginia Office of Miners Health and Safety
 47 Players Club Drive-Suite 2
 Charleston WV, 25311-1626

RE: South Hollow Plant
 MSHA 103K Order 9169301/WVOMHS&T Control Order Dated 06/07/2019
 MSHA ID: 46-03085
 WVOMHST ID: L-00000966
 Kanawha County, WV

Dear Sir:

Kanawha Eagle's Mining LLC's, South Hollow Plant plans to install the following two systems in compliance with the approved action plan.

Visual Disconnect

A visual disconnect system will be installed and maintained on the high voltage feed for the 1st and 8th floor MCC rooms. The 3rd floor MCC room currently has a visual disconnect. This control allows electricians to quickly and easily disconnect the high voltage feed entering the cabinets.

Trapped Key Interlock

Trapped Key Interlocks will be installed on the visual disconnects on the 1st, 3rd, & 8th floor MCC rooms. The Trapped Key Interlock system works by releasing a key when the visual disconnect is in the open position, this key is used to open a locking mechanism that will be installed on the cabinet lid, preventing access unless the power has been removed. The key for each system will only fit the locks associated with the MCC room where it is located, the key will not be universal to all MCC rooms.

The South Hollow Plant has identified American Electrical Equipment Incorporated for products, supplies, and technical support. An onsite audit with an AEEI representative has verified compatibility with our existing system. AEEI identified components and a quote is being created with the estimated cost and lead time of the items needed. Once available the operator will provide a timeline with the expected installation of the above listed systems.

Upon availability of parts and equipment, Rogers Electric will install the systems in cooperation with AEEI.



Kanawha Eagle Mining, LLC # 0 Box 100
Canton, WV 26026
Phone: (304) 837-3400

The South Hollow Plant has a non-represented workforce. No employee or other person has volunteered or accepted the role of miners' representative. This notification has been posted at the mine office for review. If you should have any questions, please do not hesitate to call me at (304) 341-3365.

Respectfully,

A handwritten signature in black ink that reads "Chris Williams".

Chris Williams
Safety Manager

MINE PLANT INFORMATIONCOMPANY Kanawha Eagle Mining LLC.PLANT NAME: South Hollow PlantWV PERMIT L00000966 MSHA PERMIT NO. 46-03085ADDRESS PO. BX. 189 Comfort WV., 25049COUNTY Kanawha PHONE NO. 304-837-5415DATE PERMIT ISSUED 9-27-83WORKING STATUS ActiveLOCATION Winfred HollowUNION _____ NON-UNION XDAILY PRODUCTION 12,000 ANNUAL PRODUCTION TO DATE _____TOTAL EMPLOYEES 45NUMBER OF SHIFTS 2COAL SEAM NAME AND THICKNESS NA

ACCIDENT INCIDENT RATE _____ LOST TIME ACCIDENTS _____

TYPE OF HAULAGE BeltWVOMHST INSPECTOR Randy Carter, Steve BowlesDATE OF LAST INSPECTION 6-12-19

Photographs and Drawings



Photo 1.1 Outside of slope belt A drive cabinet

*Note- Disconnect handle was found to be in the closed position.



Photo 1.2 Inside of the slope belt A drive cabinet



Photo 1.3 Side view of disconnect linkage in slope belt A drive cabinet.

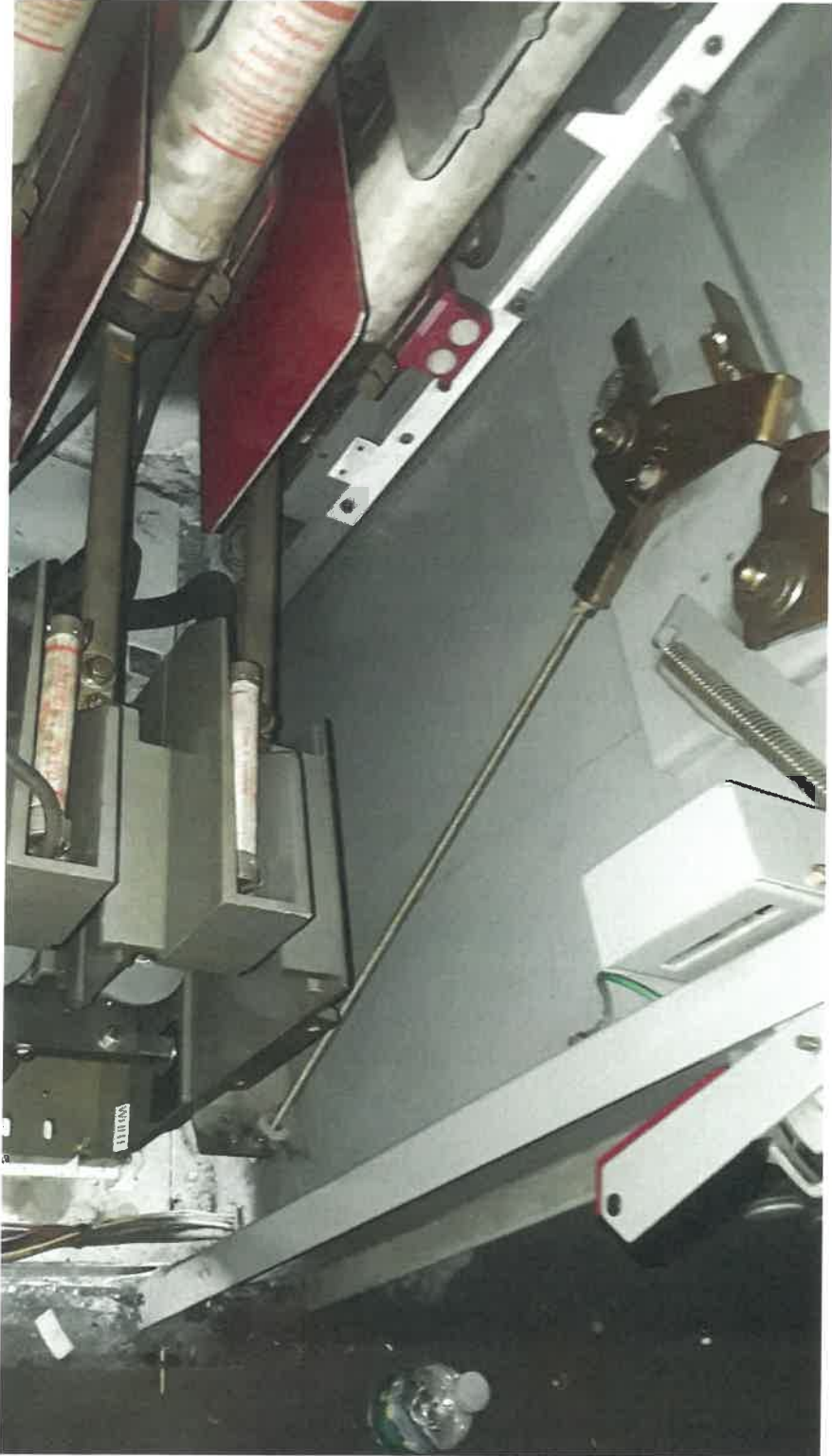
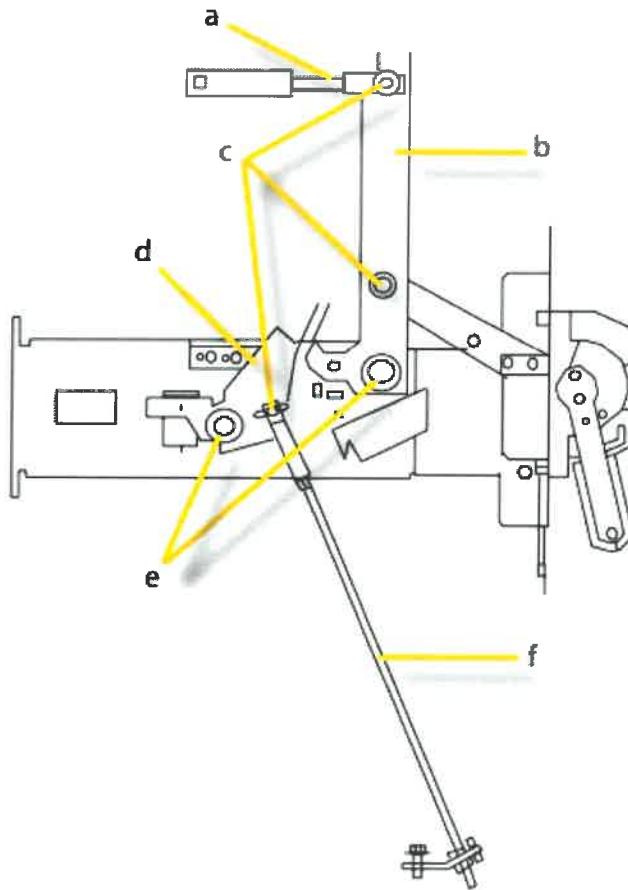

Photo 1.4 Front view of disconnect linkage in the slope belt A drive cabinet.



- a. Threaded Connecting Rod*
- b. Isolation Switch Operating Lever*
- c. Clevis Pins and Cotter Pins*
- d. Switch Interlock Lever*
- e. Lubrication Points (only at replacement)*
- f. Contactor Interlock Rod*

Photo 1.5 Photo of drawing of disconnect linkage that is in the slope belt A drive cabinet.