

West Virginia Office of Miners' Health, Safety and Training

October 20, 2006

Report of Rib Fall Fatality
Underground Coal Mine

Kingwood Mining Company, LLC
Whitetail Kittanning Mine
Permit No. U-1007-98A

Region One – Fairmont Office
205 Marion Square
Fairmont, WV 26554
Brian Mills, Inspector-at-Large

TABLE OF CONTENTS

MAP	3
GENERAL INFORMATION	4
DESCRIPTION	4, 5
FINDINGS OF FACT	5
CONCLUSION	6
ENFORCMENT ACTION	6
RECOMMENDATIONS	6
ACKNOWLEDGEMENT	7
APPENDIX	8

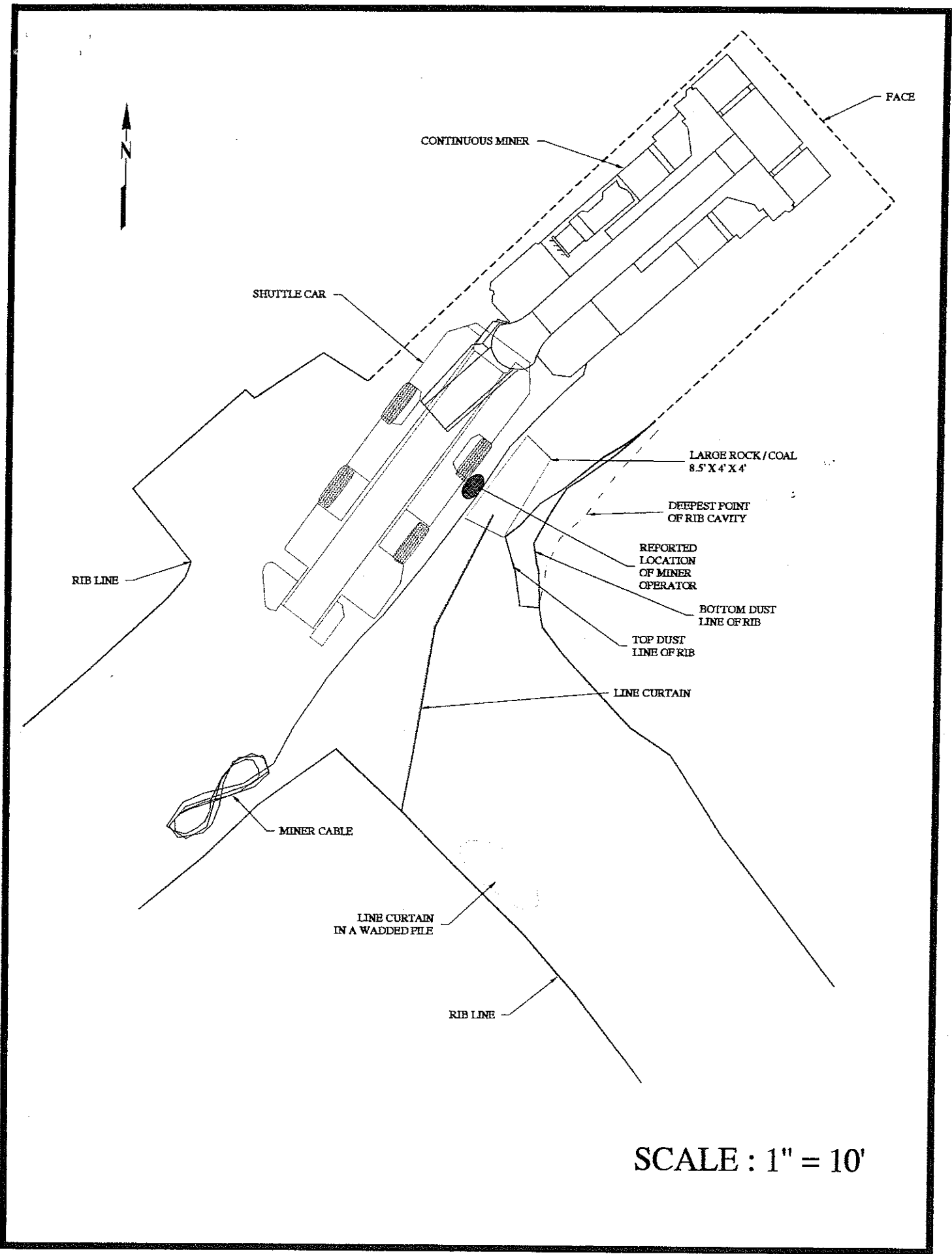

Fatal Rib Fall Accident Investigation Report
Kingwood Mining Company, LLC
Whitetail Kittanning Mine
Permit No. U-1007-98A

GENERAL INFORMATION

A fatal rib fall accident occurred at approximately 2:20 p.m. on Friday, October 20, 2006 at the Kingwood Mining Company, LLC, Whitetail Kittanning Mine. The accident occurred on the East Section where advance mining was being conducted. Thomas Channell, age 49 was struck by a large section of falling rib and pinned against a shuttle car in the No. 5 to No. 6 crosscut that was being mined. Mr. Channell had a total of twenty-seven (27) years mining experience and eleven (11) years experience at this mine.

The Preston County 911 Center was notified at 2:22 p.m. The WV Mine Safety Hotline was notified at 2:45 p.m. Kingwood Mining Company, LLC's Safety Director, Joe Pervola notified the Office of Miners' Health, Safety and Training Fairmont office of the accident at approximately 2:50 p.m. A joint investigation with the Mine Safety and Health Administration and Kingwood Mining Company, LLC was started immediately.

A regular inspection was ongoing at the mine at the time of the accident.

DESCRIPTION

The Kingwood Mining Company, LLC, Whitetail Mine is a shaft and slope opening mine producing coal from the Lower Kittanning seam. The mine is located near Fellowsville on Route 26 in Preston County, West Virginia. The average mining height is approximately 78 inches and the coal is transported to the surface by conveyor belt. The company employs 245 people and 27 contractors on two (2) production shifts and one (1) maintenance shift. Continuous mining methods are currently being used on the four (4) sections that have two (2) continuous miner units each.

The East Section crews entered the mine under the direction of left side foreman, Art Wilt and right side foreman, Fred Watson at 7:00 a.m. on Friday, October 20, 2006. The men traveled by battery powered rail personnel carriers and arrived at the section at approximately 7:45 a.m. After a safety meeting the left side crew began production in the No. 4 Entry, mining continued without incident throughout the shift, in the following places #3-#2 crosscut, No. 3 Entry, #5-#6 crosscut, No. 4 Entry, #2-#1 crosscut, No. 3 Entry and the #5-#6 crosscut. After the #5-#6 crosscut was mined the first time it was then bolted by roof bolters, Brian J. Casteel and Jamie Blaney. Also apprentice miner Ryan Kilkenny put in one bolt on the corner. After the #5-#6 crosscut bolting was completed section mechanic, Mike Hardy obtained the scoop from the section utilityman, Max Burgoyne, Jr., who went to lunch. Mr. Hardy scooped the #5-#6 crosscut, when Mr. Burgoyne returned from lunch he took a bag of dust from the scoop and rockdusted the #5-#6 crosscut. Mr. Hardy took the scoop to get oil for the bolt machine. Mr.

Hardy came back with the scoop and proceeded to deliver the oil to the bolt machine. Mr. Burgoyne took the scoop to the No. 4 Entry where he began to clean that entry.

At approximately 1:50 p.m. Mr. Channell began operating the continuous mining machine in the #5-#6 crosscut. Mr. Wilt arrived at the #5-#6 crosscut at 2:10 p.m. to make his two (2) hour exam. After making his examination Mr. Wilt told Mr. Channell after mining was completed in the #5-#6 crosscut to move to the No. 4 Entry. Mr. Wilt then proceeded to the mine phone to meet Mr. Watson to prepare to call out the section pre-shift report to the surface.

Ben Belanger and Steve Chappell, both left side shuttle car operators started hauling out of the #5-#6 crosscut. Mr. Belanger stated that he pulled under the boom of the continuous miner to get the cleanup load. Mr. Channell started loading the shuttle car at that time. Mr. Belanger stated he looked down in the deck of the shuttle car and he heard something give way, he shut off the shuttle car and called out to Mr. Channell. Mr. Channell did not respond. Mr. Belanger got off the shuttle car, raised up the curtain and saw that a large piece of coal/rock had fell and Mr. Channell was pinned against the shuttle car. Mr. Belanger ran down the No. 5 Entry to summon help. Mr. Belanger first contacted Mr. Chappell, then on to Frank Keener, right side shuttle car operator, who telephoned outside. At this time Mr. Wilt and Mr. Belanger went back to the accident scene. Mr. Chappell notified Mr. Burgoyne, Mr. Casteel and Mr. Blaney, who all went to the accident scene. Mr. Hardy also came to the accident scene along with workers from the right side of the section. Lifting jacks were used to free Mr. Channell, the effort lasted 30 to 40 minutes. When notified outside E.M.T.'s from throughout the mine were sent to the accident scene. After Mr. Channell was freed he was transported to the track by rubber-tired vehicle and then onto the outside by rail. Once outside he was transported by ambulance to the Preston Memorial Hospital where he was pronounced dead by Preston County Coroner, Mrs. Pam Thomas.

An on-site investigation was started on October 20, 2006 and continued on October 21, 2006 with technical assistance provided by WV Miners' Health, Safety and Training Chief Engineer, Monte Hieb.

FINDINGS OF FACT

1. The victim was struck by a coal and rock rib fall pushing him into the shuttle car.
2. The piece of material that struck the victim was approximately 96" in length and 4' in width and 4' in height.
3. Prior to the accident the victim was standing approximately 12' outby the last row of roof bolts in the #5-#6 crosscut.
4. The shuttle car involved in the accident was a Joy Model 10SC32, serial # No. 40C018.
5. Mining started in #5-#6 crosscut at 1:50 p.m. and had proceeded 27' in depth.
6. Please see the excerpt of a draft report written by Chief Engineer, Monte Hieb.

CONCLUSION

While operating the continuous miner in the #5-#6 crosscut on the East Section, Mr. Thomas Channell was fatally injured when he was struck by a falling section of coal and rock rib that pushed him into a shuttle car.

ENFORCEMENT ACTIONS

A Non-Assessed Control Order was issued in accordance with Title 36, Series 19, Section 7.1 of the West Virginia Mining Laws, Rules and Regulations. To preserve the accident scene.

The WV Miners' Health, Safety and Training issued Four (4) Notice of Violations during this investigation. One (1) is considered to have contributed directly to the accident.

It reads as follows:
West Virginia Code 22A-2-25(a)

It was revealed during the investigation of a fatal accident that the rib was not supported or controlled adequately to protect persons from a fall of the rib. Mr. Thomas Channell suffered fatal injuries when a large section of rib fell which pinned him against a shuttle car. The falling section of rib measured approximately 96" in length x 4' high and 4' in width.

RECOMMENDATIONS

The roof control plan shall be revised to address current mining conditions. Management shall train all employees on the revisions of the roof control plan. An addendum has been added to the roof control plan and is attached in the appendix.

APPENDIX

*	Mine Information	9
*	Victim Information	10
*	List of Persons Providing Information/ or Present During the Investigation	11 - 13
*	Excerpt of a draft report written by Chief Engineer, Monte Hieb	14 - 17
*	Roof Control Addendum dated October 25, 2006	18 - 21
*	Copy of Contributing Violation	22
*	Copies of the Non-Contributing Violations and Abatements	23 - 27

MINE INFORMATION

COMPANY NAME: Kingwood Mining Company, LLC

MINE NAME: Whitetail Kittanning

WV PERMIT: U-1007-98A

ADDRESS: Route 1, Box 294C, Newburg, WV 26410

COUNTY: Preston

DATE PERMIT ISSUED: October 23, 2003 WORKING STATUS: Active

LOCATION: Near Fellowville, WV

UNION: _____ NON-UNION: X

DAILY PRODUCTION: 6,000 Ton

ANNUAL PRODUCTION TO DATE: 946,356 Ton

TOTAL EMPLOYEES: 245 NUMBER OF SHIFTS: 3

NAME OF COAL BED: Lower Kittanning

SEAM THICKNESS: 78"

ACCIDENT INCIDENT RATE: 2.01 LOST TIME ACCIDENTS: 9

TYPE OF HAULAGE: Shuttle Car -- Belt Conveyor

WV OMHST INSPECTOR: David Barlow

DATE OF LAST INSPECTION: On-Going

NOTIFIED BY: Joe Pervola

TIME OF NOTIFICATION: 2:50 p.m.

CMSP – ANNIVERSARY DATE: October 21, 2006

CMSP – CONTACT PERSON: Frank Matras

INVESTIGATION

The following persons were present for the on-site investigation conducted on October 20, 2006:

KINGWOOD MINING COMPANY, LLC

Frank Matras	President
Perry Ryan	Superintendent
Robert M. Beatty	Dinsmore & Shohl (Attorney)
Joe Swerbinsky	Mine Engineer
Joe Pervola	Safety Director

MINE SAFETY AND HEALTH ADMINISTRATION

Jerry Vance	MSHA Specialist/Training
Jan B. Lyall	MSHA Inspector/Roof Bolter
Jeff Maxwell	MSHA Inspector

WV MINERS' HEALTH, SAFETY AND TRAINING

Terry Farley	Administrator
Mark Wilfong	Assistant Inspector-at-Large
David Barlow	District Mine Inspector
Barry Fletcher	Roof Control Inspector
John Scott	Electrical Inspector

ALLEGHENY SURVEYS, INC.

Dewayne A. Hall	Senior Party Chief
Timothy Brake	Surveyor
Steve Haskell	Surveyor

INVESTIGATION

The following persons were present during the on-site investigation conducted on October 21, 2006:

KINGWOOD MINING COMPANY, LLC

Frank Matras	President
Perry Ryan	Superintendent
Joe Pervola	Safety Director
Earl Inscore	Safety
Robert Beatty	Attorney

MINE SAFETY AND HEALTH ADMINISTRATION

Nelson Blake	Chief Roof Control Section
Mike Gauna	Mining Engineer/Tech Support/Roof Control

WV MINERS' HEALTH, SAFETY AND TRAINING

Mark Wilfong	Assistant Inspector-at-Large
Barry Fletcher	Roof Control Inspector
Monte Hieb	Chief Engineer

INTERVIEWS

The following persons were present during interviews conducted on October 23, 2006:

KINGWOOD MINING COMPANY, LLC

Frank Matras	President/General Manager
Perry Ryan	Superintendent
Joe Pervola	Safety Director
Carol Ann Marinich	Dinsmore & Shohl (Attorney)
Robert H. Beatty	Dinsmore & Shohl (Attorney)
*Arthur Wilt	Acting Section Foreman
*Michael A. Hardy	Section Mechanic
*Max Burgoyne, Jr.	Utilityman
*Steve Chappell	Shuttle Car Operator
*Benjamin Belanger	Shuttle Car Operator
*Brian J. Casteel	Roof Bolter Operator
*Jamie Blaney	Roof Bolter Operator

*Denotes Interviewed

MINE SAFETY AND HEALTH ADMINISTRATION

Jan Lyall	MSHA Inspector/Roof Control
Jerry Vance	MSHA Specialist.Training

WV MINERS' HEALTH, SAFETY AND TRAINING

Terry Farley	Administrator
Mark Wilfong	Assistant Inspector-at-Large
David Barlow	District Mine Inspector

The following is an excerpt of a draft report written by Chief Engineer, Monte Hieb:

Upon examination of the rib slab and the place from which it slipped it was apparent that it failed and fell out due to two intersecting, highly slickensided **intersecting angled slip planes** which bounded the top and bottom of the rib slab, creating a geometry whereby the slab was essentially a free-body which became dislodged when the slip planes were severed at the ends in the normal course of mining, first at the corner, then on the other end as the cross-cut was being driven.



Photo 3: Looking at the bottom slip plane in rib from vantage point of where shuttle car was stationed.

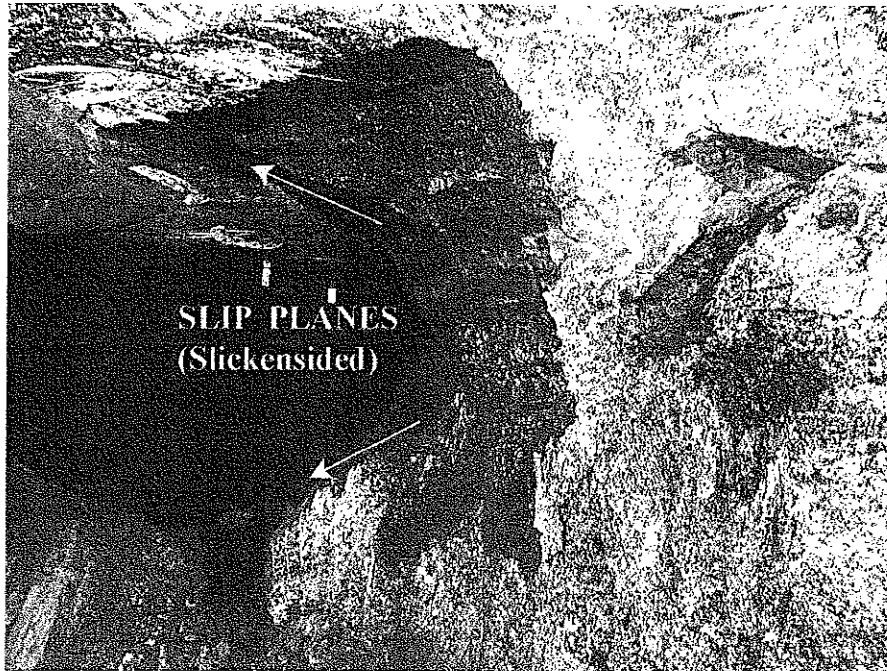

Photo 4: View of corner rib slips. Photo taken from the intersection of #5 Entry at #40 Cross-cut.. Fallen rib slab in lower left corner. Upper and lower slip planes bounded the rib slab that fell out.

Photo 3 is a front-facing view of the corner rib that failed. The bearing of the lower slickensided failure plane trends N 22°E and its slickensided surface dips toward the open cross-cut in a northwesterly direction. **Photo 4** is looking at 90° to the view shown in Photo 3 and is also the vantage for the illustrations of dimensions and angles shown in **Figures 2 and 3**.

The steep and highly slickensided surface of the lower failure plane is the primary reason for the sudden and unexpected failure of the rib slab. A slip plane angled at 42° poses a high degree of risk from horizontal forces trying to kick out a stationary rock mass due to its own weight. In conjunction the slickensided upper failure plane vertically intersects and is horizontally parallel to it, which allowed the rib block to break free.

After the intersecting slip planes were mined-through in both the entry and in the turned cross-cut the resisting forces holding the rib slab in place were reduced to only three things: 1) the tensile strength of the carbonaceous shale Parting (see **Figure 2**), 2) the cohesion forces of the top failure plane, 3) and the shear-resisting frictional forces along the lower slickensided failure plane. These forces were not sufficient to resist the free-body forces acting horizontally on the slab, which are estimated at 1/3 to 1/2 of the 5-ton estimated weight of the rib slab.

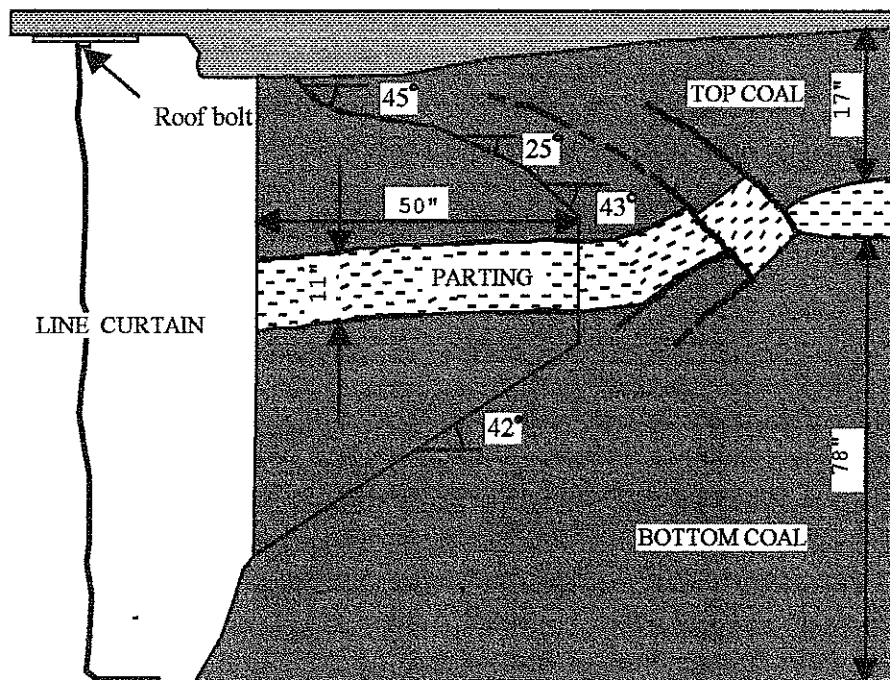

Figure 2: This is a schematic view (from the vantage point of Photo 4) that shows the dimensions and bounded by intersecting slip planes as it likely looked prior to failure.

Due to the steepness of the lower slip plane the slab failure probably gave little if any advance warning of what it was about to do. The direction of movement would have been essentially perpendicular to the strike of the lower slip plane surface—approximately in the direction of N 68°W, although one side may have given way slightly before the other. Based on the evidence, it appears the outby end probably gave way first, rotating slightly about a pivot point near the inby end. Although the single rib slab is approximately 8-ft. in length, the total rib failure involved a length of about 17-ft., comprised of material that is now broken into 5-7 moderate-sized rectangular pieces and additional smaller pieces.

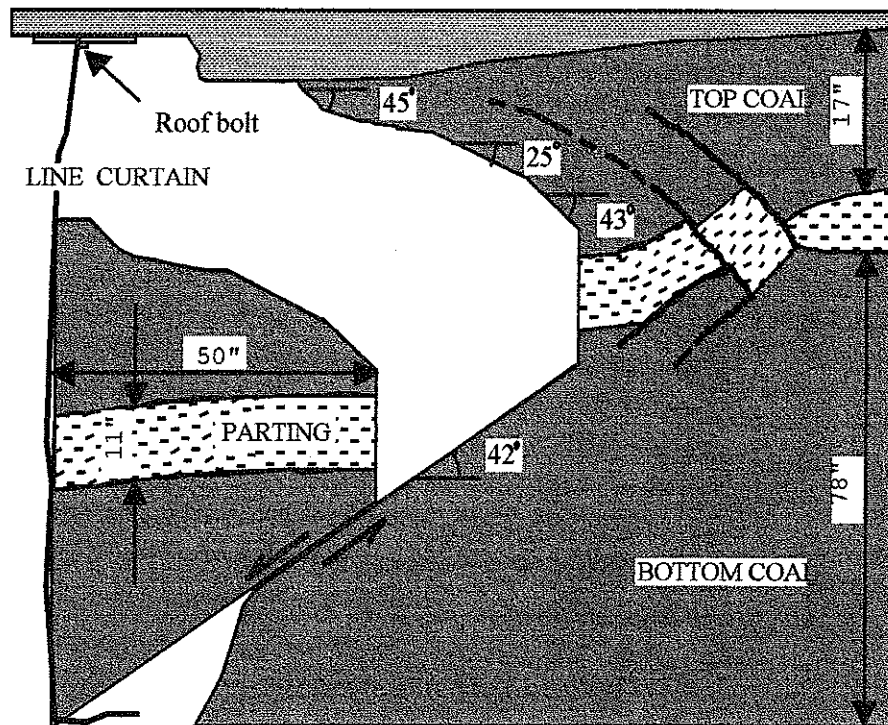

Figure 3: This is a schematic drawing showing the believed mode of failure of the rib slab. This view is standing in the intersection of #5 entry with # 40 cross-cut looking down #40 cross-cut in the direction of #6 entry (see Figure 2 for “before picture”).

**STATE OF WEST VIRGINIA
OFFICE OF MINERS' HEALTH, SAFETY AND TRAINING
BUREAU OF COMMERCE
205 MARION SQUARE
FAIRMONT WV 26554**

Region One

October 25, 2006

COMPANY: Kingwood Mining Company, LLC

ADDRESS: Route 1, Box 264C, Newburg, WV 26410

This is to acknowledge receipt of your Roof Control Plan for:

Whitetail Kittanning U-1007-98A
Mine Permit No.

Your submitted change has been:

Accepted

Rejected

REMARKS: Your requested revision to your roof control plan has been reviewed and approved.
(Letter and Drawing dated Oct. 25, 2006)

RE: Revision to your roof control addendum dated Oct. 24, 2006.

David Barlow
District Inspector

Barry Fletcher
Roof Control Inspector

Mark Wilfong
Inspector-At-Large



Kingwood Mining Company, LLC
Route 1 Box 294C, Newburg WV 26410
Phone: 304-568-2460 Fax: 304-568-2465

October 25, 2006

West Virginia Office of Miners' Health Safety and Training
205 Marion Square
Fairmont, WV 26554

Attn: Mr. Brian Mills, Inspector at Large

For: Whitetail K-Mine -- WV ID No. U-1007-98A

Subject: Intersecting Planes

Dear Sir:

Kingwood Mining Company LLC, requests this revision to our previously approved plan dated October 24, 2006 and hereby proposes the following measures be implemented in an attempt to prevent a reoccurrence of the events of October 20, 2006:

1. The #1 & #10 entry projections will be dropped for the remainder of the East Section Panel (approximately 800-1000 feet). This is being done to reduce, by twenty-one per cent, (21%), the exposure time of employees to unforeseen slips and clay veins and where intersecting angle shear planes are present in the roof and ribs.
2. During the mining cycle and thereafter, frequent visual examinations will be conducted, prior to rock dusting, emphasizing the recognition of unforeseen slips and clay veins where intersecting angle shear planes are present in the roof and ribs. A training and education PowerPoint presentation will be demonstrated to employees with an emphasis on conducting frequent visual examinations and the recognition of unforeseen slips and clay veins and where intersecting shear planes are present. These examinations will be reviewed with all Kingwood employees and incorporated into Kingwood's Comprehensive Safety Program.
3. If slips and clay veins where intersecting angle shear planes are present and identified, such conditions will either be scaled down or controlled. If the condition cannot be scaled down with a slate bar or the continuous miner, measures to control the condition will be as follows:

Slips and clay veins where intersection angle shear planes are present they will be scaled, controlled or supported by utilizing 60" rib/brow angle straps made of T-3 channel bent to an approximately 60° angle and installed as illustrated in Drawing #1A, attached. These supplemental roof and rib supports, as identified in Drawing #1A, are site specific and pertain only to the geological anomalies (slips and clay veins and where intersecting angle shear planes are present) existing in the East Section. When beginning projected crosscuts or cutting a crosscut through angle straps will not be installed. This area will be marked with red reflectors.

If intersecting angle shear planes are identified in other areas of the mine they will be scaled, controlled, or supported.

With the approval and subsequent implementation of hazard recognition training, changes in the current mining projections limiting employee exposure by twenty-one per cent (21%), and the proposed supplemental roof and rib support plan, Kingwood Mining, LLC., respectfully requests that the West Virginia Office of Miners' Health Safety and Training terminate the control order and permit normal mining operations to resume immediately.

If you have any questions, or if further information is required, feel free to contact me at (304) 568 - 2460.

Sincerely;

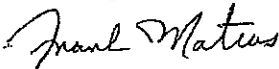

Frank Matras
President and General Manager

DRAWING 2A
TYPICAL BROW STRAP INSTALLATION (2A)

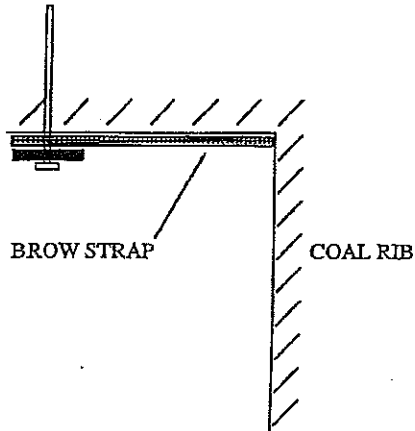

DRAWING 2B
TYPICAL ANGLE STRAP INSTALLATION

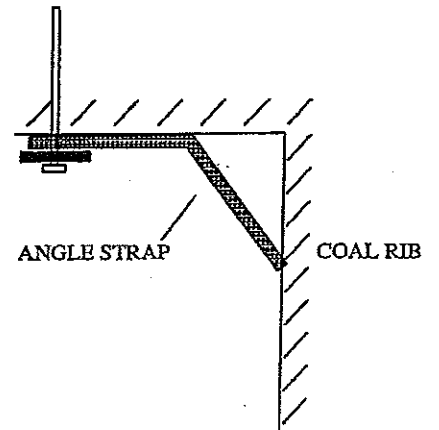

DUAL BOOM BOLTER WITH A.T.R.S.

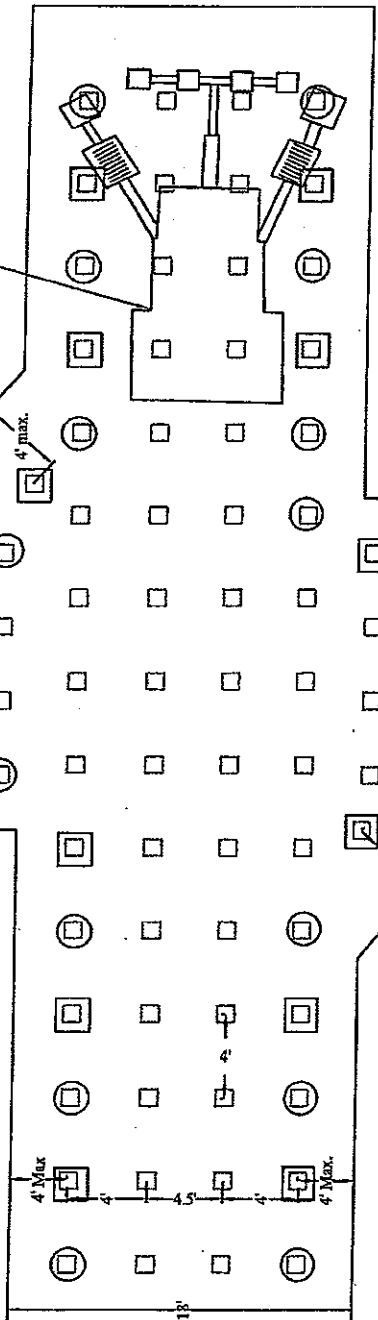

A. OUTSIDE BOLTS IN ROW "A" WILL BE INSTALLED WITH SUPPLEMENTAL BROW STRAPS AS ILLUSTRATED IN "2A", T-3 STRAPS 30" MINIMUM LENGTH IN EVERY OTHER ROW.

B. OUTSIDE BOLTS IN ROW "B" WILL BE INSTALLED WITH SUPPLEMENTAL ANGLE STRAPS AS ILLUSTRATED IN DRAWING "2B", T-3 STRAPS 60" MINIMUM LENGTH IN AT LEAST EVERY OTHER ROW OR AS NEEDED.

- ⊙ ROOFBOLT WITH BROW STRAP
- ⊠ ROOF BOLT WITH ANGLE STRAP

DRAWING NUMBER 1A

SUPPLEMENTAL ROOF/RIB
SUPPORT EAST SECTION

SCALE: 1" = 10 FT.

MFN CC-0051/

IF-C18
Revised 11-02

STATE OF WEST VIRGINIA

* CONTRIBUTING

White- Company
Blue -Inspector
Green -Charleston
Canary -Regional Office
Pink- Post
Goldenrod -Rep of Mines

OFFICE OF
MINERS' HEALTH, SAFETY AND TRAINING

1615 Washington Street East
Charleston, West Virginia 25311-2126

Region One
Case No. 150-0072-2006
Violation No. 7

NOTICE OF VIOLATION

Company / Operator Kingwood Mining Company, LLC Contractor: Yes No X
Permit Number U-1007-99A Mine Name Whitetail Kittanning
Date of Issue November 16, 2006 Time 9:00 A.M. P.M.

Notice is hereby given that the undersigned authorized representative of the Director of the Office of Miners' Health, Safety and Training, upon making an inspection of this mine finds that the violation referred to in West Virginia Code, Chapter 22A, Article 2, Section 25a and/or West Virginia Administrative Regulation: Title , Series , Section exists as follows:

It was revealed during the investigation of a fatal accident on the East Section in the #5-#6 crosscut that the rib was not supported or controlled adequately to protect persons from a fall of the rib. Mr. Thomas Channell suffered fatal injuries when a large section of rib fell which pinned him against a shuttle car. The falling section of rib measured approximately 96" in length x 4' high and 4' width.

Type of Issuance: N.O.V. X Order

Area or equipment (if order is issued):

The foregoing violation shall be totally abated by a.m. p.m. on 20

The foregoing violation was totally abated by 9:15 a.m. p.m. on Nov. 16 2006

Action taken to abate the violation: Discussion with mine management, management has retrained all effected persons and submitted an addendum to the roof control plan to address the condition.

Company / Operator Agent Served: Joe Pervola

Authorized Representative: Mark Wilberg Inspector No. 150

REVIEW: In accordance with Section 22A-1-17 of the Code, an operator or any representative of the miners may apply to the Director of the Office of Miners' Health, Safety and Training for review of this notice of violation within thirty (30) days from the issued date.

VIOLATION ASSESSMENT EVALUATION

Recommend Special Assessment:

Likelihood of Occurrence: Unlikely: *(0) Reasonably likely (10) Occurred (20) X

Severity of Injury Expected: None: *(0) No lost work days *(6) Lost or restricted days (11)
Permanently disabling (15) Fatal (20) X

No. of Persons Potentially Affected: 0 (0) 1 (1) X 2 (2) 3 (4) 4-5 (6) 6-9 (8) 9+ (10)

Negligence: None (0) Low (10) X Moderate (15) High (20)

Knowing Violation: No X Yes Repeat

Good Faith in Abatement: Lack of good faith (+15%)

No compliance (extenuating circumstances) (0%) X Extra effort (15%)